

# CONTENEDORES

Fabricado a partir de polietileno de alta densidad (PAD) inyectado según la norma EN840.

Cuenta con refuerzos en forma de panal de abeja en el cuello de la boca del contenedor, lo que le confiere una gran resistencia a las manipulaciones repetitivas. Resistente a las variaciones de temperatura, a los rayos UV y a los agentes químicos.

Los ejes de las ruedas están fabricados en acero electro-cincado resistente a la corrosión.

Cumple las normas acústicas conforme a las directivas europeas, (<99db).

Fabricado en Alemania, EU.

## CONTENEDORES PARA LA RECOGIDA SELECTIVA



### 80 Litros

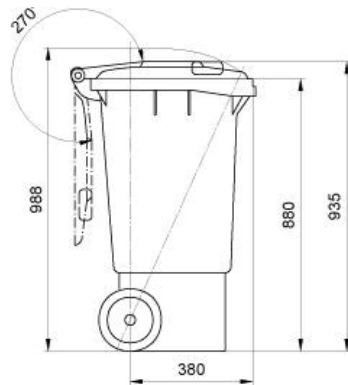
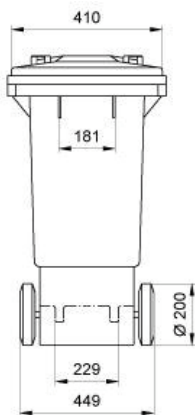
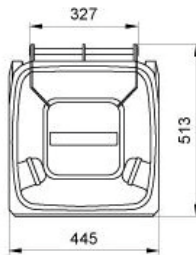

#### Dimensiones

Altura:	93,5 cm
Largo:	45 cm
Profundidad:	51,3 cm

#### Grosos

Espesor del cuerpo:	0,4 cm
Espesor del fondo:	0,45 cm
Espesor de la tapa:	0,36 cm

#### Pesos

Cuerpo:	7 Kg
Eje y ruedas:	2,6 Kg
Tapa:	0,8 Kg
Peso Total:	10 Kg

#### Volumen

Volumen útil:	80 L
Carga útil:	40 Kg

#### Despiece

- ▶ 1 cuerpo
- ▶ 1 tapa
- ▶ 1 eje de ruedas
- ▶ 2 ruedas de Ø 200 mm
- ▶ 2 clips de la tapa

# OPCIONES Y COMPLEMENTOS

Colores disponibles



RAL  
7021



RAL  
7037



RAL  
7038



RAL  
8024



RAL  
1021



RAL  
6011



RAL  
5015



RAL  
2010



RAL  
3020

## Anti-lluvia



## Barra protección



## Insonorización



## Cierre con llave

